

A
Major Project

On

PATROLLING ROBOT USING EMBEDDED C

(Submitted in partial fulfillment of the requirements for the award of Degree)

BACHELOR OF TECHNOLOGY

In

COMPUTER SCIENCE AND ENGINEERING

By

G. PRAVEESHA	(187R1A0585)
M. V. SREEMAN BHARADWAZ	(187R1A0592)
HITESH SIRVI	(187R1A0596)

Under the Guidance of

J. NARASIMHARAO

(Associate Professor)



DEPARTMENT OF COMPUTER SCIENCE AND ENGINEERING

CMR TECHNICAL CAMPUS

UGC AUTONOMOUS

(Accredited by NAAC, NBA, Permanently Affiliated to JNTUH, Approved by AICTE, New Delhi) Recognized Under Section 2(f) & 12(B) of the UGC Act.1956, Kandlakoya (V), Medchal Road, Hyderabad-501401.

2018-2022

DEPARTMENT OF COMPUTER SCIENCE AND ENGINEERING



CERTIFICATE

This is to certify that the project entitled “**PATROLLING ROBOT USING EMBEDDED C**” being submitted by **G. PRAVEESHA (187R1A0585), M. V. SREEMAN BHARADWAZ (187R1A0592) & HITESH SIRVI (187R1A0596)** in partial fulfillment of the requirements for the award of the degree of B.Tech in Computer Science and Engineering to the Jawaharlal Nehru Technological University Hyderabad, is a record of bonafide work carried out by him/her under our guidance and supervision during the year 2021-22. It is certified that they have completed the project satisfactorily. The results embodied in this thesis have not been submitted to any other University or Institute for the award of any degree or diploma.

J. Narasimharao
(Associate Professor)
INTERNAL GUIDE

Dr. A. RAJI REDDY
DIRECTOR

Dr. K. Srujan Raju
HOD

EXTERNAL EXAMINER

Submitted for viva voice Examination held on _____

ACKNOWLEDGEMENT

Apart from the efforts of us, the success of any project depends largely on the encouragement and guidelines of many others. We take this opportunity to express our gratitude to the people who have been instrumental in the successful completion of this project.

We take this opportunity to express my profound gratitude and deep regard to my guide **J. Narasimharao**, Associate Professor for his exemplary guidance, monitoring and constant encouragement throughout the project work. The blessing, help and guidance given by him shall carry us a long way in the journey of life on which we are about to embark.

We also take this opportunity to express a deep sense of gratitude to the Project Review Committee (PRC) **Mr. A. Uday Kiran, Mr. J. Narasimharao, Dr. T. S. Mastan Rao, Mrs. G. Latha & Mr. A. Kiran Kumar**, for their cordial support, valuable information and guidance, which helped us in completing this task through various stages.

We are also thankful to **Dr. K. Srujan Raju**, Head, Department of Computer Science and Engineering for providing encouragement and support for completing this project successfully.

We are obliged to **Dr. A. Raji Reddy**, Director for being cooperative throughout the course of this project. We also express our sincere gratitude to Sri. **Ch. Gopal Reddy**, Chairman for providing excellent infrastructure and a nice atmosphere throughout the course of this project.

The guidance and support received from all the members of **CMR Technical Campus** who contributed to the completion of the project. We are grateful for their constant support and help.

Finally, we would like to take this opportunity to thank our family for their constant encouragement, without which this assignment would not be completed. We sincerely acknowledge and thank all those who gave support directly and indirectly in the completion of this project.

G. PRAVEESHA (187R1A0585)

M. V. SREEMAN BHARADWAZ (187R1A0592)

HITESH SIRVI (187R1A0596)

ABSTRACT

Nowadays Safety and rules are the biggest concern in many parts of the world. There are certain areas where women are being harassed, raped, etc. Not to mention that people don't obey the traffic rules or do not wear helmets. Considering the present scenario where the world just has come out of Covid 19 and yet to deal with its variants like Delta variant and Omicron as well, it is important that people wear masks. All these rules are just followed only if people are under surveillance due to their negligence. Unfortunately there are no CCTVs in all areas. It is not possible for the government to keep an eye on each person. The police officer may not patrol all areas. So here we propose a Patrolling robot an IOT based robot vehicle so that they can monitor all the surrounding areas from one particular area. The robot uses cameras mounted on robotic vehicles for monitoring of premises. It provides continuous monitoring through live broadcasting of the surroundings. This project focuses on a robot that is designed for the purpose of patrolling and surveillance of people in small areas or colonies where police officers do not usually patrol and no CCTVs to monitor people who are deviating from the rules in certain areas taking advantage of the fact that police officers do not patrol in such areas.

LIST OF FIGURES

FIGURE NO	FIGURE NAME	PAGE NO
Figure 2.5.1.1	L293D Motor Driver	7
Figure 2.5.1.2	ESP 32 CAM	8
Figure 2.5.1.3	DC Motors	8
Figure 3.1	Architecture Of Patrolling Robot Using Embedded C	10
Figure 3.2	Connections	11
Figure 3.3	Use case diagram for Patrolling Robot Using Embedded C	12
Figure 3.4	Class diagram for Patrolling Robot Using Embedded C	13
Figure 3.5	Sequence diagram for Patrolling Robot Using Embedded C	14
Figure 3.6	Activity diagram for Patrolling Robot Using Embedded C	15
Figure 3.7	Data Flow diagram for Patrolling Robot Using Embedded C	16

LIST OF SCREENSHOTS

SCREENSHOT NO	SCREENSHOT NAME	PAGE NO
Screenshot 5.1.1	Top View of Robot	24
Screenshot 5.1.2	Side View Of Robot	25
Screenshot 5.1.3	Front View Of Robot	26
Screenshot 5.1.4	Rare View Of Robot	27
Screenshot 5.2.1	GUI Of Model	28
Screenshot 5.2.2	Live Streaming Captured By The Robot	29
Screenshot 5.3	GUI in mobile and live streaming under low light	30
Screenshot 5.4	Functioning with LED on and off respectively	31

LIST OF TABLES

TABLE NO	TABLE NAME	PAGE NO
Table 2.5.1	Hardware Requirements	7
Table 6.1	Results Of Working Of Robot	33

TABLE OF CONTENTS

ABSTRACT	i
LIST OF FIGURES	ii
LIST OF SCREENSHOTS	iii
LIST OF TABLES	iv
1.INTRODUCTION	1
1.1 PROJECT SCOPE	1
1.2 PROJECT PURPOSE	2
1.3 PROJECT FEATURES	2
2.SYSTEM ANALYSIS	3
2.1 PROBLEM DEFINITION	3
2.2 EXISTING SYSTEM	3
2.2.1 LIMITATIONS OF THE EXISTING SYSTEM	4
2.3 PROPOSED SYSTEM	4
2.3.1ADVANTAGES OF PROPOSED SYSTEM	4
2.4 FEASIBILITY STUDY	5
2.4.1 ECONOMIC FEASIBILITY	5
2.4.2 TECHNICAL FEASIBILITY	6
2.4.3 BEHAVIORAL FEASIBILITY	6
2.5 HARDWARE & SOFTWARE REQUIREMENTS	6
2.5.1 HARDWARE REQUIREMENTS	6
2.5.2 SOFTWARE REQUIREMENTS	9
3.ARCHITECTURE	10
3.1 PROJECT ARCHITECTURE	10
3.2 DESCRIPTION	10
3.3 USE CASE DIAGRAM	12
3.4 CLASS DIAGRAM	13
3.5 SEQUENCE DIAGRAM	14
3.6 ACTIVITY DIAGRAM	15
3.7 DATA FLOW DIAGRAM	16
4.IMPLEMENTATION	17
4.1 SAMPLE CODE	17

5.SCREENSHOTS	24
6.TESTING	32
6.1 INTRODUCTION TO TESTING	32
6.2 TYPES OF TESTING	32
6.2.1 UNIT TESTING	32
6.2.2 INTEGRATION TESTING	32
6.2.3 FUNCTIONAL TESTING	32
6.3 TEST CASES	33
6.3.1 WORKING OF ROBOT	33
7. CONCLUSION & FUTURE SCOPE	34
7.1 PROJECT CONCLUSION	34
7.2 FUTURE SCOPE	34
8. REFERENCES	35
8.1 REFERENCES	35
8.2 GITHUB LINK	35

1. INTRODUCTION

1. INTRODUCTION

1.1 PROJECT SCOPE

This project is titled “Patrolling Robot Using Embedded C”. This robot helps users i.e police officers to patrol and monitor the small areas where people tend to ignore traffic rules, not wearing masks as we can see, cases of Covid-19 and Omicron variant are increasing day by day and also harassing women and many such incidents can be monitored. As there are no CCTVs in such areas, this would help reduce such cases and maintain the integrity of the citizens. They say rules are important for one’s growth and discipline and also safety is a concern for many. Is there a guarantee that these two or not be compromised? We do know that there are CCTVs only in certain areas and it is also not possible to implement them in all the areas right away. What is the problem with not having CCTV in areas? There are numerous problems like people deviating from rules such as not wearing masks, theft, suspicious persons, looking for wanted criminals, safety, abnormal events [1] etc. There is a need for a system that minimizes these issues, at least to a certain extent. The suggested robot helps users i.e., police officers or any other individual using it, to patrol and monitor the small areas where people tend to ignore traffic rules, not wearing masks as we can see, cases of COVID-19 and its variants are increasing day by day and also harassing women and many such incidents can be monitored. As there are no CCTVs in such areas, this would help reduce such cases and maintain the integrity of the citizens. The purpose is to patrol and surveillance of people in small areas or colonies where police officers do not usually patrol and to monitor people who are deviating from the rules in certain areas, taking advantage of the fact that police officers do not patrol in such areas. Individuals can also use it for purposes like home surveillance and building security. The main feature of this model is that the system uses an ESP32 CAM which is programmed and placed on the robot vehicle for monitoring its surroundings. The model can be operated using a mobile while

connected to Wi-Fi and works within the range of the network it is connected to. The user controls this to monitor the live streaming. To patrol at night, an LED light is attached to the robot.

1.2 PROJECT PURPOSE

This project has been developed to focus on a robot that is designed solely to serve the purpose of patrolling and surveillance of people in small areas or colonies where police officers do not usually patrol and to monitor people who are deviating from the rules in certain areas taking advantage of the fact that police officers do not patrol in such areas.

1.3 PROJECT FEATURES

The main feature of this project is that the system uses a camera mounted on the robotic vehicle for monitoring surroundings. The robot vehicle can be easily operated using mobile while connected to Wifi. This is controlled by the user to monitor the live streaming. To patrol at night, an LED light is attached to the robot.

2. SYSTEM ANALYSIS

2. SYSTEM ANALYSIS

SYSTEM ANALYSIS

System Analysis is the important phase in the system development process. The System is studied to the minute details and analyzed. In analysis, a detailed study of these operations performed by the system and their relationships within and outside the system is done. A key question considered here is, “what must be done to solve the problem?” The system is viewed as a whole and the inputs to the system are identified. Once analysis is completed the analyst has a firm understanding of what is to be done.

2.1 PROBLEM DEFINITION

We do know that there are CCTVs only in certain areas and it is also not possible to implement them in all the areas right away. What is the problem of not having CCTV in areas? There are numerous problems like people deviating from rules, not wearing masks, theft, suspicious persons, looking for wanted criminals, safety, etc. There is a need for a system that minimizes these issues at least to a certain point.

2.2 EXISTING SYSTEM

There are certain areas where there are more chances of not obeying the traffic rules. Not to mention the present scenario where the world just has come out of Covid 19 and yet to deal with its variants like Delta variant and Omicron as well, people must wear masks and many more issues. All these rules are just followed only if people are under surveillance due to their negligence. Unfortunately, there are no CCTVs in such areas which is an advantage to people who neglect the rules.

2.2.1 LIMITATIONS OF EXISTING SYSTEM

Following are the limitations of the existing system:

- Police aren't able to patrol all the places.
- It is not easy to patrol at night time.
- No CCTVs in all areas.

2.3 PROPOSED SYSTEM

We propose a Patrolling robot, IOT based where the system uses cameras mounted on the robot vehicle for securing or monitoring any premises. It provides continuous monitoring through live broadcasting of the site from mobile. This is controlled by police officers to monitor the live streaming and when he/she sees something abnormal then the police officer can directly go to that specific location. This project focuses on a robot that is designed solely to serve the purpose of providing security and surveillance of people in small areas or colonies where police officers do not usually patrol and to monitor people who are deviating from the rules in certain areas taking advantage of the fact that police officers do not patrol in such areas. This is like a movable surveillance robot, which is designed for patrolling purposely only.

2.3.1 ADVANTAGES OF THE PROPOSED SYSTEM

The following are the advantages of the proposed system:

- Police aren't able to patrol all the places this robot will help the police to just watch the streaming from a remote location.
- The robot vehicle is Controllable.
- Easy to use.

- Includes the Light to make surroundings visible at night.
- The device is movable covering the surroundings.

2.4 FEASIBILITY STUDY

The feasibility of the project is analyzed in this phase and the business proposal is put forth with a very general plan for the project and some cost estimates. During system analysis, the feasibility study of the proposed system is to be carried out. This is to ensure that the proposed system is not a burden to the company. Three key considerations involved in the feasibility analysis:

- Economic Feasibility
- Technical Feasibility
- Social Feasibility

2.4.1 ECONOMIC FEASIBILITY

The developing system must be justified by cost and benefit. Criteria to ensure that effort is concentrated on a project, which will give best, return at the earliest. One of the factors, which affect the development of a new system, is the cost it would require. The following are some of the important financial questions asked during the preliminary investigation:

- The costs conduct a full system investigation.
- The cost of the hardware and software.
- The benefits are in the form of reduced costs or fewer costly errors.

Since the system is developed as part of project work, there is no manual cost to spend for the proposed system. Also, all the resources are already available, which gives an indication that the system is economically possible for development.

2.4.2 TECHNICAL FEASIBILITY

This study is carried out to check the technical feasibility, that is, the technical requirements of the system. Any system developed must not have a high demand on the available technical resources. The developed system must have a modest requirement, as only minimal or null changes are required for implementing this system.

2.4.3 BEHAVIORAL FEASIBILITY

This includes the following questions:

- Is there sufficient support for the users?
- Will the proposed system cause harm?

The project would be beneficial because it satisfies the objectives when developed and installed. All behavioral aspects are considered carefully and conclude that the project is behaviorally feasible.

2.5 HARDWARE & SOFTWARE REQUIREMENTS

2.5.1 HARDWARE REQUIREMENTS:

Hardware interfaces specify the logical characteristics of each interface between the software product and the hardware components of the system.

The following are some hardware requirements:

MATERIAL	QUANTITY
ESP 32 CAM	1
L293D Motor Driver	2
Robo Case	1
Motor Wheels	2
DC Motors 200rpm	2
Battery	2
Wifi	-
Connecting Wires	-

Table 2.5.1:Hardware Requirements

2.5.1.1 L293D Motor Driver

L293D is an Integrated Chip which comprehends two H-Bridge and PWM. It comprises 16 pins with 8 pins on either side. The H-Bridge is used for rotation whereas the PWM deals with the speed of motors. The L293D motor driver drives two motors and provides a two-wheel robot vehicle functioning. It has capacitors to protect the circuit from Back EMF produced by the motors because of their inductive load. The 4 GND pins act as a heat sink as the heat is generated during high current flow.

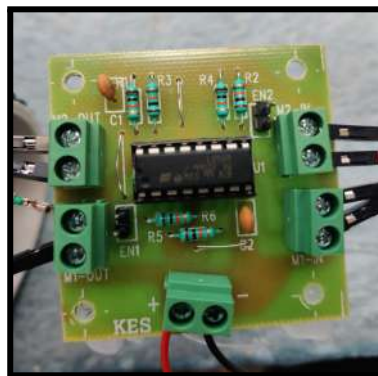

Figure 2.5.1.1 L293D Motor Driver

2.5.1.2 ESP32 CAM

It is a camera module comprising an ESP32-S chip [8]. It has several GPIO pins enabling it to connect add-ons or other devices. It has the feature of a microSD card slot which stores the captured images and makes those available to users. The ESP32 CAM is programmed and we embed the code using FTDI cable through serial pins.



Figure 2.5.1.2 ESP 32 CAM

2.5.1.3 DC Motors

Direct-Current motors are machines which make use of electrical power to convert electrical energy into mechanical energy for rotating the wheels.

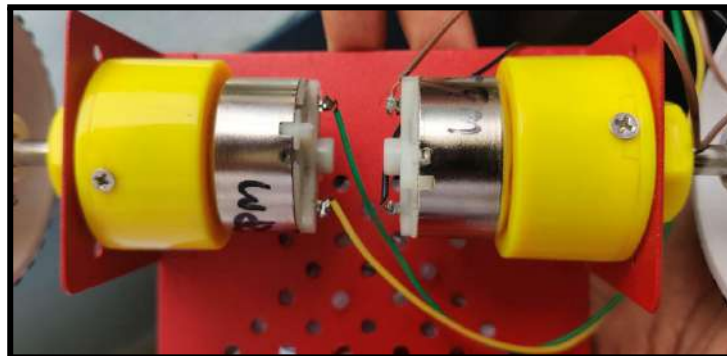

Figure 2.5.1.3 DC Motors

2.5.2 SOFTWARE REQUIREMENTS:

Software Requirements specifies the logical characteristics of each interface and software components of the system. The following are some software requirements:

- IDE: Arduino IDE
- Languages: Embedded C, CPP
- OS: Windows 7 and above

3. ARCHITECTURE

3. ARCHITECTURE

3.1 PROJECT ARCHITECTURE

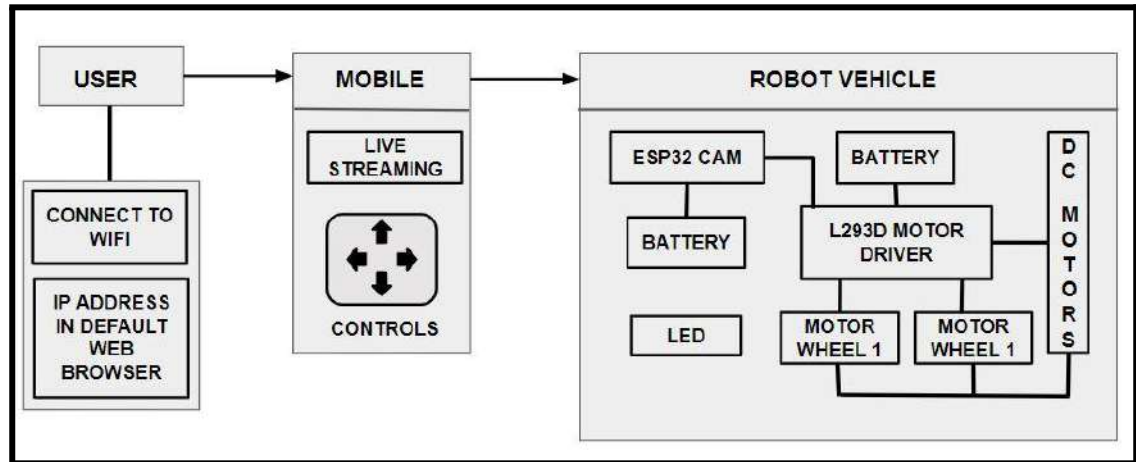

Figure 3.1 Architecture of Patrolling Robot Using Embedded C

3.2 DESCRIPTION

The mobile acts as an interface between the user and robot vehicle. The user can operate the robot vehicle through mobile. The user has to connect to Wifi. Later the user has to open the given IP Address in his/her default web browser which directs them to a page where the controls and live streaming are displayed.

The robot vehicle consists of two motor wheels that are connected to two DC motors. The L293D motor driver is used to drive these two DC motors in any direction. The ESP 32 CAM is placed on the top of the robot vehicle, which is used for live streaming purposes. This ESP 32 CAM is programmed using Embedded C language. The L293D motor driver is connected to ESP32 Cam to protect it from back EMF. Both ESP32 Cam and L293D motor driver are connected to batteries respectively. As the user uses the control keys, the robot vehicle moves by providing live streaming to the user.

3.2.1 Connections

The two wheels are connected to the DC motors of 300rpm and these DC motors are connected to the output pins of the L293D motor driver. The L293D motor driver is an H-bridge type for which the power supply is given through the rechargeable battery and allows the bi-directional movement of wheels. The motor driver prevents back EMF. The ESP32 CAM is programmed using embedded C language. The L293D motor driver comprises four input pins (IN1, IN2, IN3, IN4) which are connected to GPIO pins of ESP32 CAM, respectively [10]. The output pins (M1-OUT, M2-OUT) of the L293D motor driver are connected to each of the DC motors at 300rpm. The DC motors are attached to respective wheels for their movement. We give the power supply to ESP32 CAM through the battery. The ESP32 CAM works in both Wi-Fi and Bluetooth, here we used Wi-Fi.

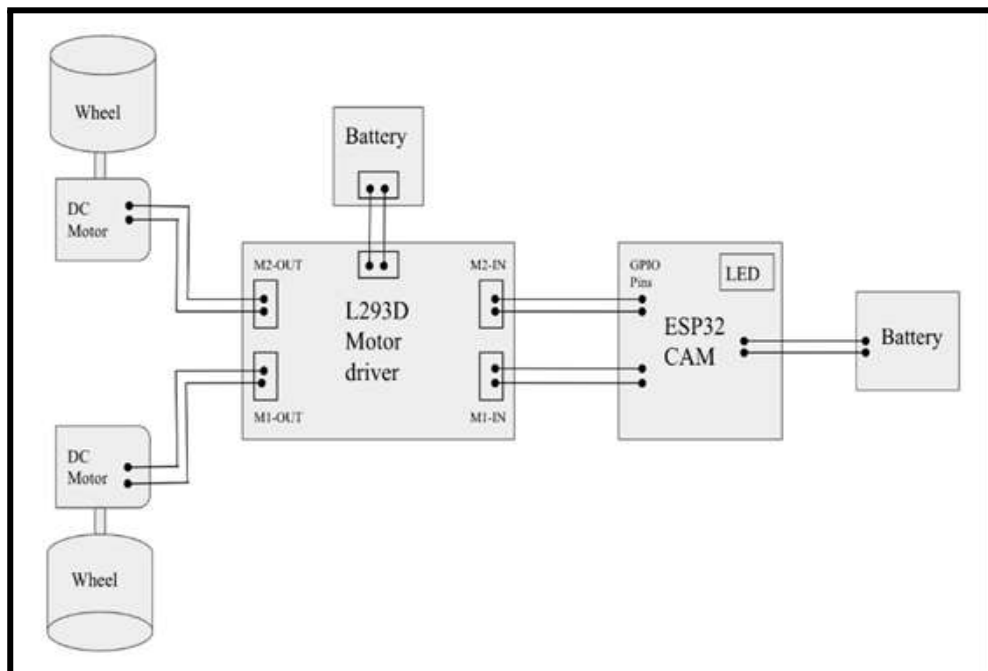

Figure 3.2 Connections

3.3 USE CASE DIAGRAM

In the use case diagram, we have three actors who are the user, the mobile, and the robot vehicle. The user operates the robot vehicle through mobile. The user controls the robot using mobile and live streaming is available on user mobile which is visible to the user. The robot moves as per the user controls.

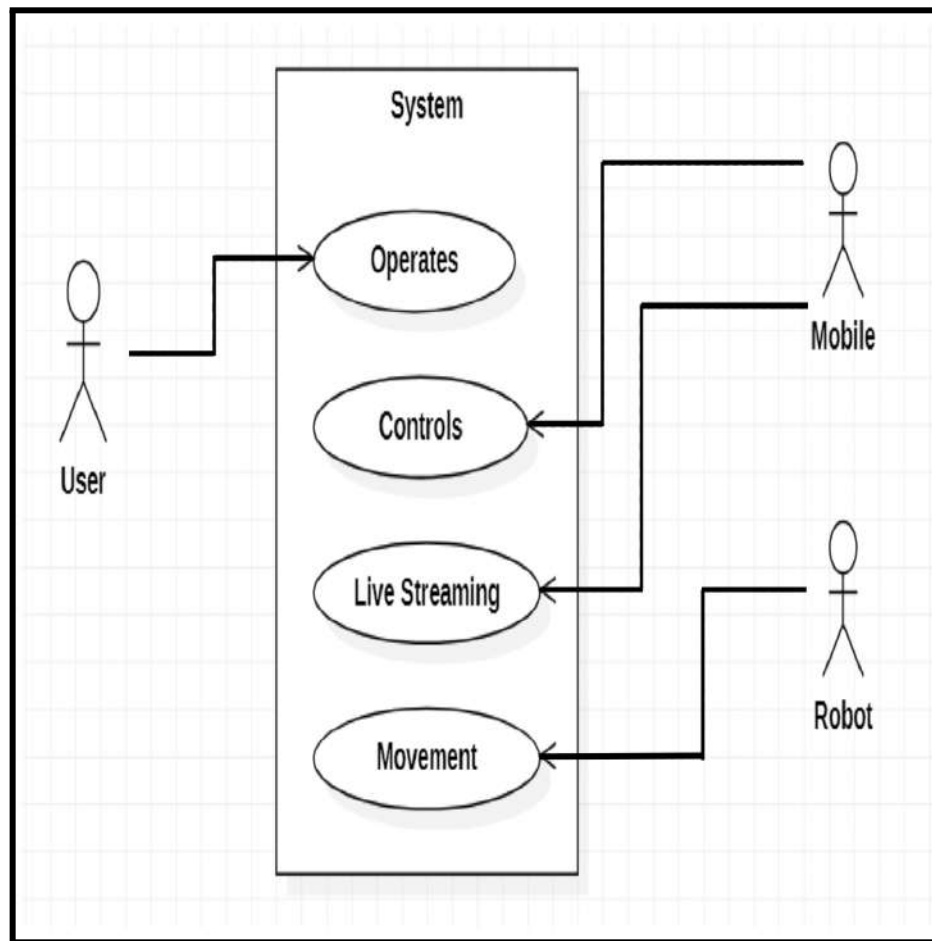

Figure 3.3 Use Case Diagram for Patrolling Robot Using Embedded C

3.4 CLASS DIAGRAM

Class Diagram is a collection of classes and objects. The user class consists of attributes name, profession, department and has operations of Operates and Observe. The mobile class consists of attributes type, wifi, password and has operations of Controlling and Live Streaming. The robot class consists of attribute type and has operations of Movement, Light and Captures.

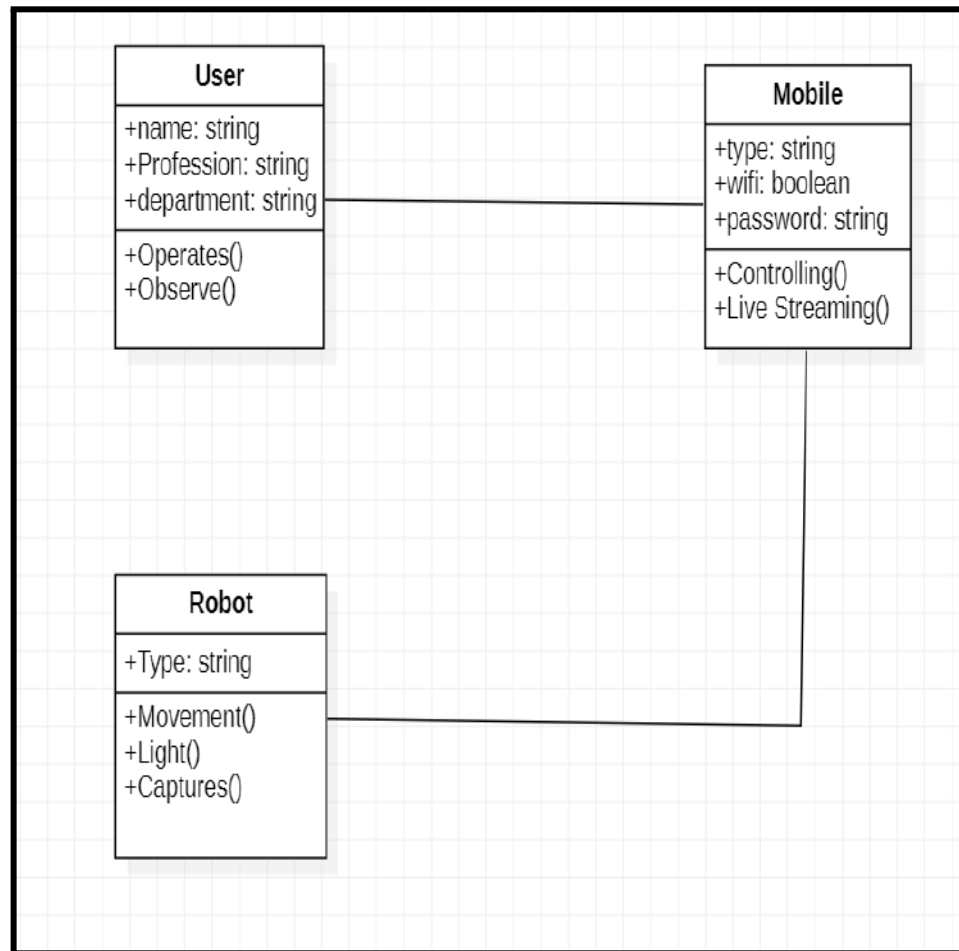

Figure 3.4 Class Diagram for Patrolling Robot Using Embedded C

3.5 SEQUENCE DIAGRAM

The below Figure 3.4 depicts the Sequence diagram of Patrolling Robot Using Embedded C. Sequence Diagrams are interaction diagrams that detail how operations are carried out. They capture the interaction between objects in the context of a collaboration.

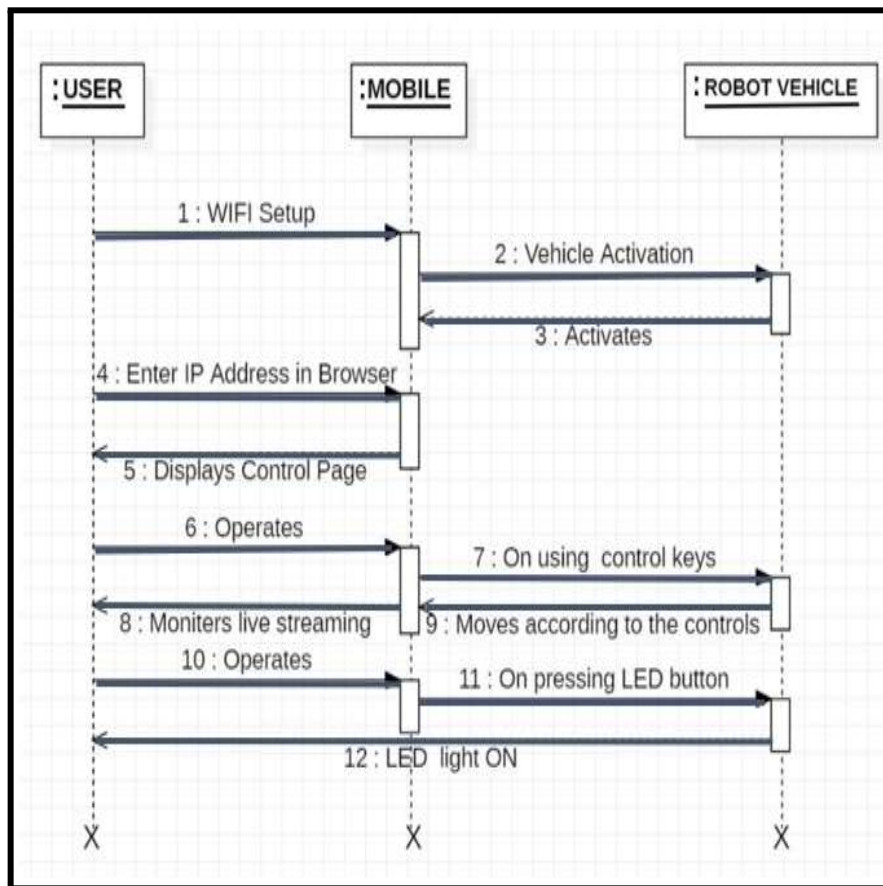

Figure 3.5 Sequence Diagram for Patrolling Robot Using Embedded C

3.6 ACTIVITY DIAGRAM

The activity diagram describes the flow of activity states. Activity diagram is basically a flowchart to represent the flow from one activity to another activity. The activity can be described as an operation of the system. The control flow is drawn from one operation to another. This flow can be sequential, branched, or concurrent.

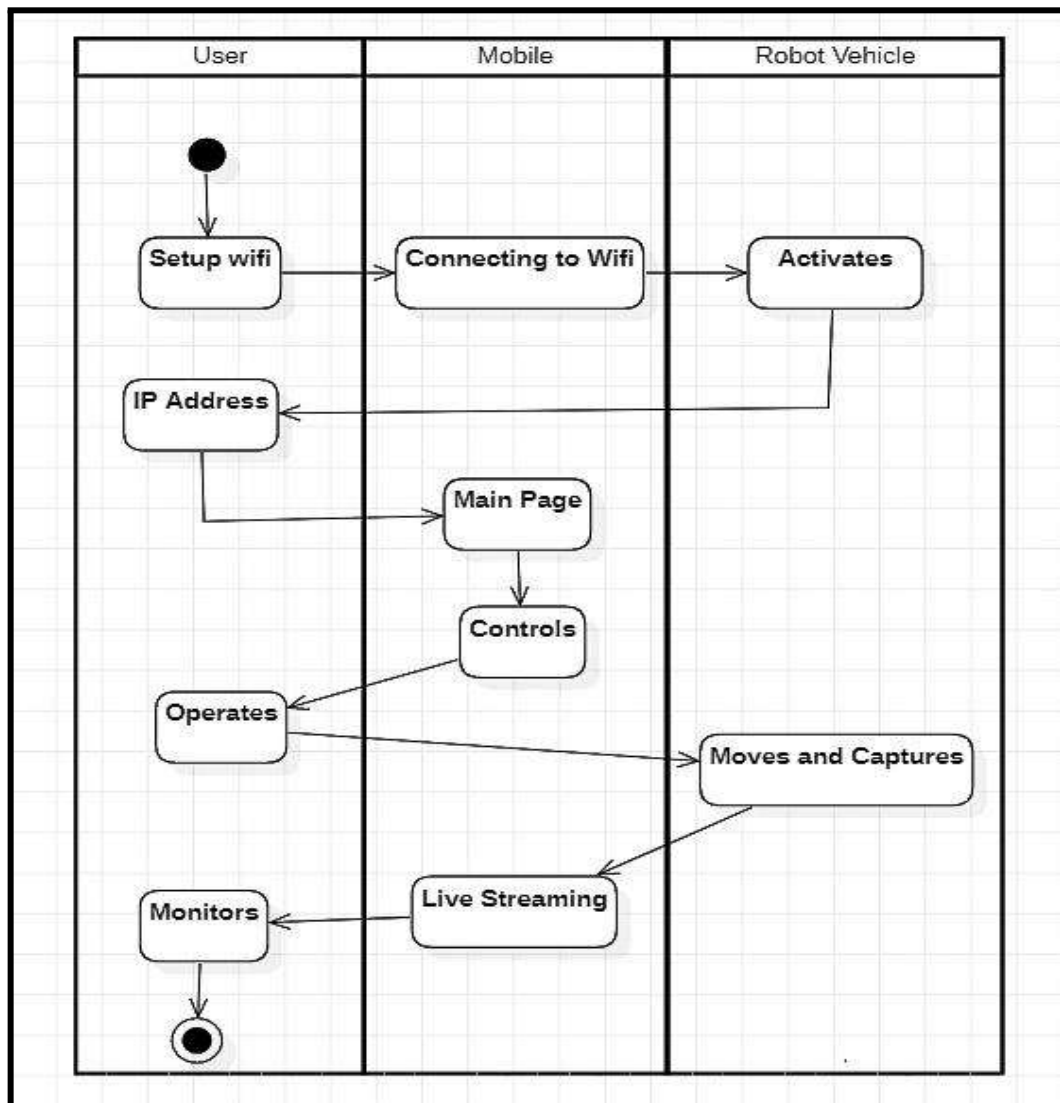

Figure 3.6 Activity Diagram for Patrolling Robot Using Embedded

3.7 DATA FLOW DIAGRAM

A data flow diagram (DFD) maps out the flow of information for any process or system. It uses defined symbols like rectangles, circles and arrows, plus short text labels, to show data inputs, outputs, storage points and the routes between each destination. Data flowcharts can range from simple, even hand-drawn process overviews, to in-depth, multi-level DFDs that dig progressively deeper into how the data is handled. They can be used to analyze an existing system or model a new one.

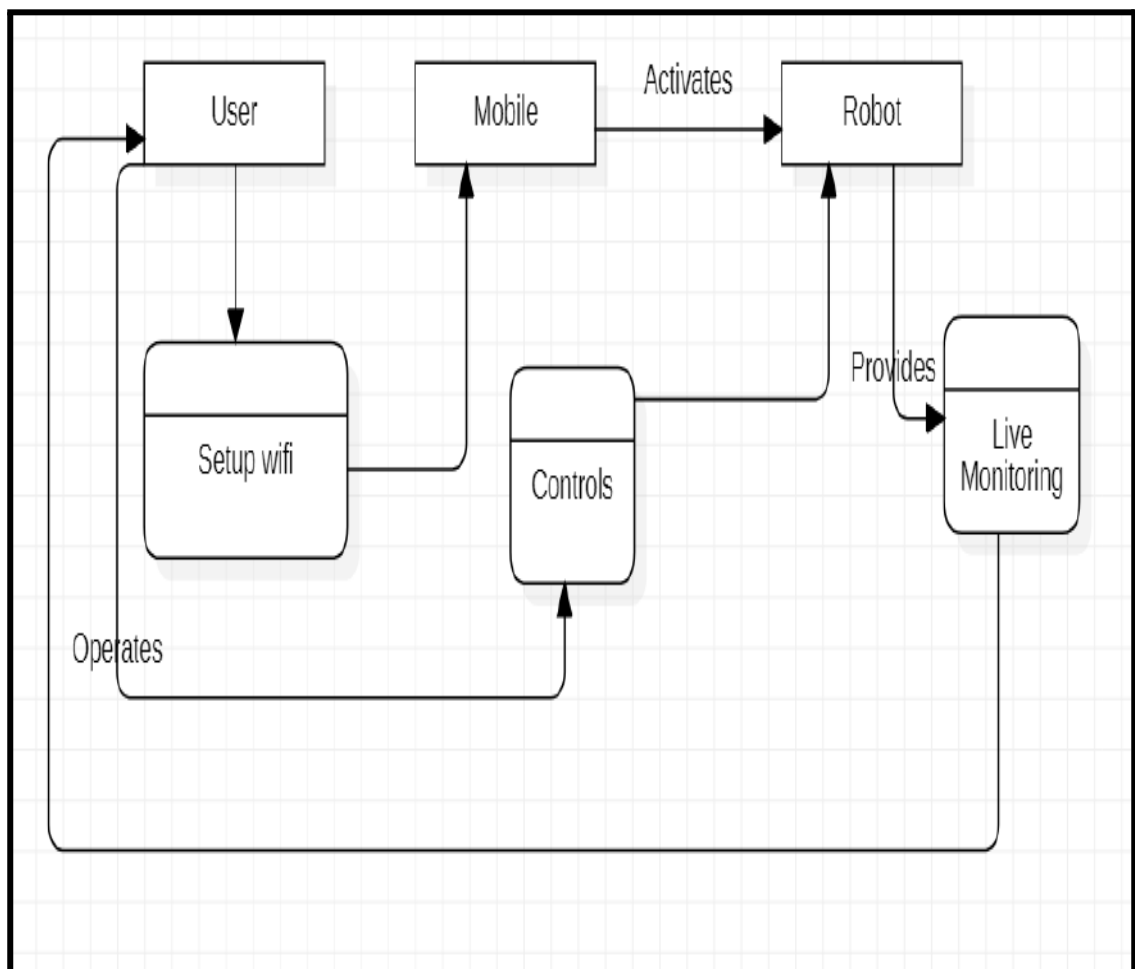

Figure 3.7 Data Flow Diagram for Patrolling Robot Using Embedded C

4. IMPLEMENTATION

4.1 SAMPLE CODE

```

//ESP32 Camera Surveillance Car

#include "esp_camera.h"
#include <WiFi.h>

//
// WARNING!!! Make sure that you have either selected ESP32 Wrover Module,
//           or another board which has PSRAM enabled
//
// Adafruit ESP32 Feather

// Select camera model
//#define CAMERA_MODEL_WROVER_KIT
//#define CAMERA_MODEL_M5STACK_PSRAM
#define CAMERA_MODEL_AI_THINKER

const char* ssid = "elegant"; //Enter SSID WIFI Name
const char* password = "smartwork"; //Enter WIFI Password

#if defined(CAMERA_MODEL_WROVER_KIT)
#define PWDN_GPIO_NUM    -1
#define RESET_GPIO_NUM  -1
#define XCLK_GPIO_NUM   21
#define SIOD_GPIO_NUM   26
#define SIOC_GPIO_NUM   27

#define Y9_GPIO_NUM     35
#define Y8_GPIO_NUM     34
#define Y7_GPIO_NUM     39
#define Y6_GPIO_NUM     36
#define Y5_GPIO_NUM     19
#define Y4_GPIO_NUM     18
#define Y3_GPIO_NUM     5
#define Y2_GPIO_NUM     4
#define VSYNC_GPIO_NUM  25
#define HREF_GPIO_NUM   23
#define PCLK_GPIO_NUM   22

#elif defined(CAMERA_MODEL_AI_THINKER)
#define PWDN_GPIO_NUM    32
#define RESET_GPIO_NUM  -1
#define XCLK_GPIO_NUM    0
#define SIOD_GPIO_NUM   26
#define SIOC_GPIO_NUM

```

```

#define Y9_GPIO_NUM    35
#define Y8_GPIO_NUM    34
#define Y7_GPIO_NUM    39
#define Y6_GPIO_NUM    36
#define Y5_GPIO_NUM    21
#define Y4_GPIO_NUM    19
#define Y3_GPIO_NUM    18
#define Y2_GPIO_NUM    5
#define VSYNC_GPIO_NUM 25
#define HREF_GPIO_NUM  23
#define PCLK_GPIO_NUM  22

#else
#error "Camera model not selected"
#endif

// GPIO Setting
extern int gpLb = 2; // Left 1
extern int gpLf = 14; // Left 2
extern int gpRb = 15; // Right 1
extern int gpRf = 13; // Right 2
extern int gpLed = 4; // Light
extern String WiFiAddr = "";

void startCameraServer();

void setup() {
  Serial.begin(115200);
  Serial.setDebugOutput(true);
  Serial.println();

  pinMode(gpLb, OUTPUT); //Left Backward
  pinMode(gpLf, OUTPUT); //Left Forward
  pinMode(gpRb, OUTPUT); //Right Forward
  pinMode(gpRf, OUTPUT); //Right Backward
  pinMode(gpLed, OUTPUT); //Light

  //initialize
  digitalWrite(gpLb, LOW);
  digitalWrite(gpLf, LOW);
  digitalWrite(gpRb, LOW);
  digitalWrite(gpLed, LOW);
  camera_config_t config;
  config.ledc_channel = LEDC_CHANNEL_0;
  config.ledc_timer = LEDC_TIMER_0;

```

```

config.pin_d0 = Y2_GPIO_NUM;
config.pin_d1 = Y3_GPIO_NUM;
config.pin_d2 = Y4_GPIO_NUM;
config.pin_d3 = Y5_GPIO_NUM;
config.pin_d4 = Y6_GPIO_NUM;
config.pin_d5 = Y7_GPIO_NUM;
config.pin_d6 = Y8_GPIO_NUM;
config.pin_d7 = Y9_GPIO_NUM;
config.pin_xclk = XCLK_GPIO_NUM;
config.pin_pclk = PCLK_GPIO_NUM;
config.pin_vsync = VSYNC_GPIO_NUM;
config.pin_href = HREF_GPIO_NUM;
config.pin_sscb_sda = SIOD_GPIO_NUM;
config.pin_sscb_scl = SIOC_GPIO_NUM;
config.pin_pwdn = PWDN_GPIO_NUM;
config.pin_reset = RESET_GPIO_NUM;
config.xclk_freq_hz = 20000000;
config.pixel_format = PIXFORMAT_JPEG;
//init with high specs to pre-allocate larger buffers
if(psramFound()){
    config.frame_size = FRAMESIZE_UXGA;
    config.jpeg_quality = 10;
    config.fb_count = 2;
} else {
    config.frame_size = FRAMESIZE_SVGA;
    config.jpeg_quality = 12;
    config.fb_count = 1;
}

// camera init
esp_err_t err = esp_camera_init(&config);
if (err != ESP_OK) {
    Serial.printf("Camera init failed with error 0x%x", err);
    return;
}

//drop down frame size for higher initial frame rate
sensor_t * s = esp_camera_sensor_get();
s->set_framesize(s, FRAMESIZE_CIF);

WiFi.begin(ssid, password);

while (WiFi.status() != WL_CONNECTED) {
    delay(500);
    Serial.print(".");
}

```



```

Serial.println("");
Serial.println("WiFi connected");

startCameraServer();

Serial.print("Camera Ready! Use 'http://'");
Serial.print(WiFi.localIP());
WiFiAddr = WiFi.localIP().toString();
Serial.println(" to connect");
}

void loop() {
  // put your main code here, to run repeatedly:

}

static esp_err_t capture_handler(httpd_req_t *req){
  camera_fb_t * fb = NULL;
  esp_err_t res = ESP_OK;
  int64_t fr_start = esp_timer_get_time();

  fb = esp_camera_fb_get();
  if (!fb) {
    Serial.printf("Camera capture failed");
    httpd_resp_send_500(req);
    return ESP_FAIL;
  }

  httpd_resp_set_type(req, "image/jpeg");
  httpd_resp_set_hdr(req, "Content-Disposition", "inline; filename=capture.jpg");

  size_t fb_len = 0;
  if(fb->format == PIXFORMAT_JPEG){
    fb_len = fb->len;
    res = httpd_resp_send(req, (const char *)fb->buf, fb->len);
  } else {
    jpg_chunking_t jchunk = {req, 0};
    res = frame2jpg_cb(fb, 80, jpg_encode_stream, &jchunk)?ESP_OK:ESP_FAIL;
    httpd_resp_send_chunk(req, NULL, 0);
    fb_len = jchunk.len;
  }
  esp_camera_fb_return(fb);
}

```

```

    int64_t fr_end = esp_timer_get_time();
    Serial.printf("JPG: %uB %ums", (uint32_t)(fb_len), (uint32_t)((fr_end -
fr_start)/1000));
    return res;
}

static esp_err_t stream_handler(httpd_req_t *req){
    camera_fb_t * fb = NULL;
    esp_err_t res = ESP_OK;
    size_t _jpg_buf_len = 0;
    uint8_t * _jpg_buf = NULL;
    char * part_buf[64];

    static int64_t last_frame = 0;
    if(!last_frame) {
        last_frame = esp_timer_get_time();
    }

    res = httpd_resp_set_type(req, _STREAM_CONTENT_TYPE);
    if(res != ESP_OK){
        return res;
    }

    while(true){
        fb = esp_camera_fb_get();
        if (!fb) {
            Serial.printf("Camera capture failed");
            res = ESP_FAIL;
        } else {
            if(fb->format != PIXFORMAT_JPEG){
                bool jpeg_converted = frame2jpg(fb, 80, &_jpg_buf, &_jpg_buf_len);
                esp_camera_fb_return(fb);
                fb = NULL;
                if(!jpeg_converted){
                    Serial.printf("JPEG compression failed");
                    res = ESP_FAIL;
                }
            } else {
                _jpg_buf_len = fb->len;
                _jpg_buf = fb->buf;
            }
        }
    }
    if(res == ESP_OK){
        size_t hlen = snprintf((char *)part_buf, 64, _STREAM_PART, _jpg_buf_len);
        res = httpd_resp_send_chunk(req, (const char *)part_buf, hlen);
    }
}

```

```

}
    if(res == ESP_OK){
        res = httpd_resp_send_chunk(req, (const char*)_jpg_buf, _jpg_buf_len);
    }
    if(res == ESP_OK){
        res = httpd_resp_send_chunk(req, _STREAM_BOUNDARY,
strlen(_STREAM_BOUNDARY));
    }
    if(fb){
        esp_camera_fb_return(fb);
        fb = NULL;
        _jpg_buf = NULL;
    } else if(_jpg_buf){
        free(_jpg_buf);
        _jpg_buf = NULL;
    }
    if(res != ESP_OK){
        break;
    }
    int64_t fr_end = esp_timer_get_time();

    int64_t frame_time = fr_end - last_frame;
    last_frame = fr_end;
    frame_time /= 1000;
    uint32_t avg_frame_time = ra_filter_run(&ra_filter, frame_time);
    Serial.printf("MJPG: %uB %ums (%.1ffps), AVG: %ums (%.1ffps)"
        ,(uint32_t)_jpg_buf_len,
        (uint32_t)frame_time, 1000.0 / (uint32_t)frame_time,
        avg_frame_time, 1000.0 / avg_frame_time
    );
}

last_frame = 0;
return res;
}

static esp_err_t cmd_handler(httpd_req_t *req){
    char* buf;
    size_t buf_len;
    char variable[32] = {0,};
    char value[32] = {0,};

    buf_len = httpd_req_get_url_query_len(req) + 1;
    if (buf_len > 1) {
        buf = (char*)malloc(buf_len);

```

```

if(!buf){
    httpd_resp_send_500(req);
    return ESP_FAIL;
}
if (httpd_req_get_url_query_str(req, buf, buf_len) == ESP_OK) {
    if (httpd_query_key_value(buf, "var", variable, sizeof(variable)) == ESP_OK
    &&
        httpd_query_key_value(buf, "val", value, sizeof(value)) == ESP_OK) {
    } else {
        free(buf);
        httpd_resp_send_404(req);
        return ESP_FAIL;
    }
} else {
    free(buf);
    httpd_resp_send_404(req);
    return ESP_FAIL;
}
free(buf);
} else {
    httpd_resp_send_404(req);
    return ESP_FAIL;
}

int val = atoi(value);
sensor_t * s = esp_camera_sensor_get();
int res = 0;

```

5. SCREENSHOTS

5.1 DEVELOPED PATROLLING ROBOT

Below are the images of the developed Patrolling Robot. The robot comprises L293D Motor Driver, ESP32 Cam, DC motors, two wheels, rechargeable battery, 9v battery and connecting wires.

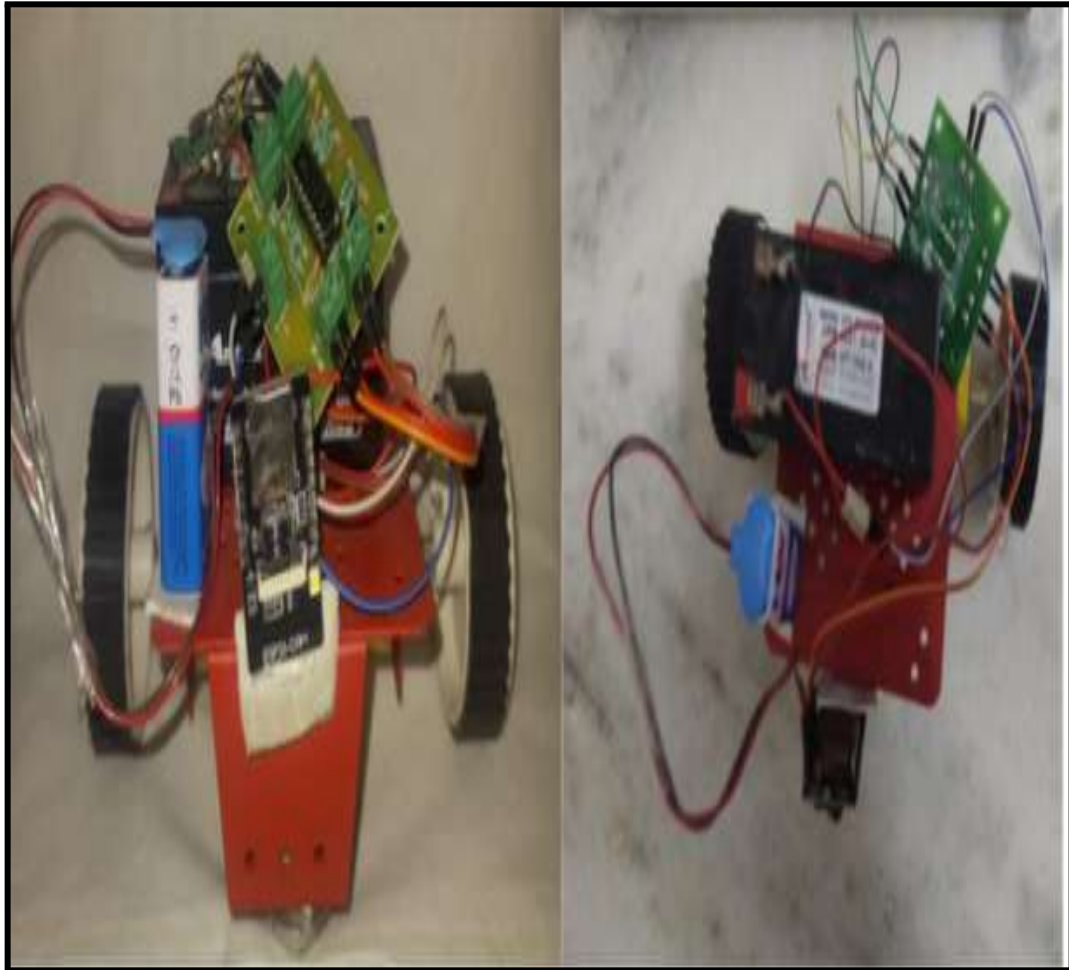

Screenshot 5.1.1 Top View of Robot

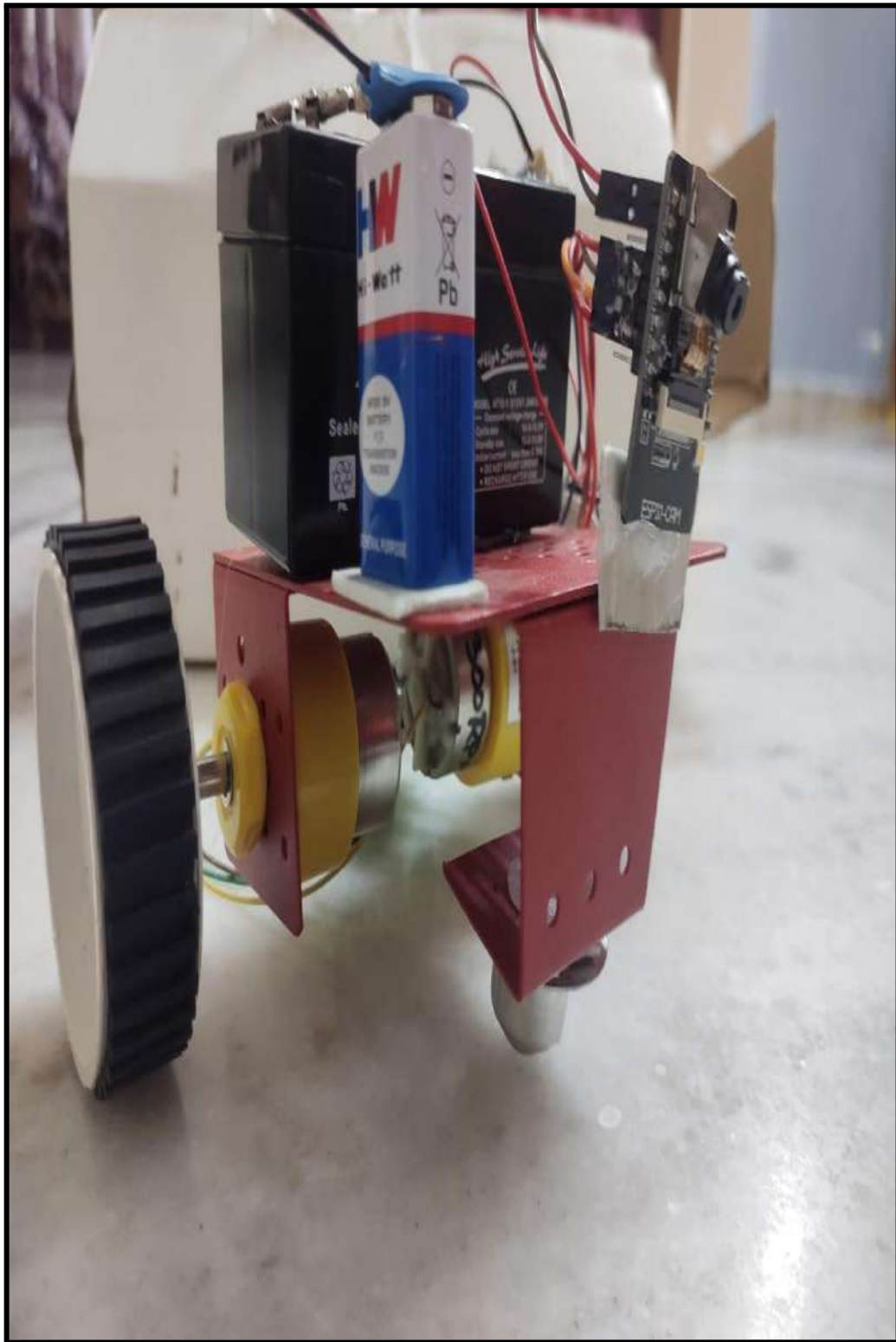

Screenshot 5.1.2 Side View Of Robot

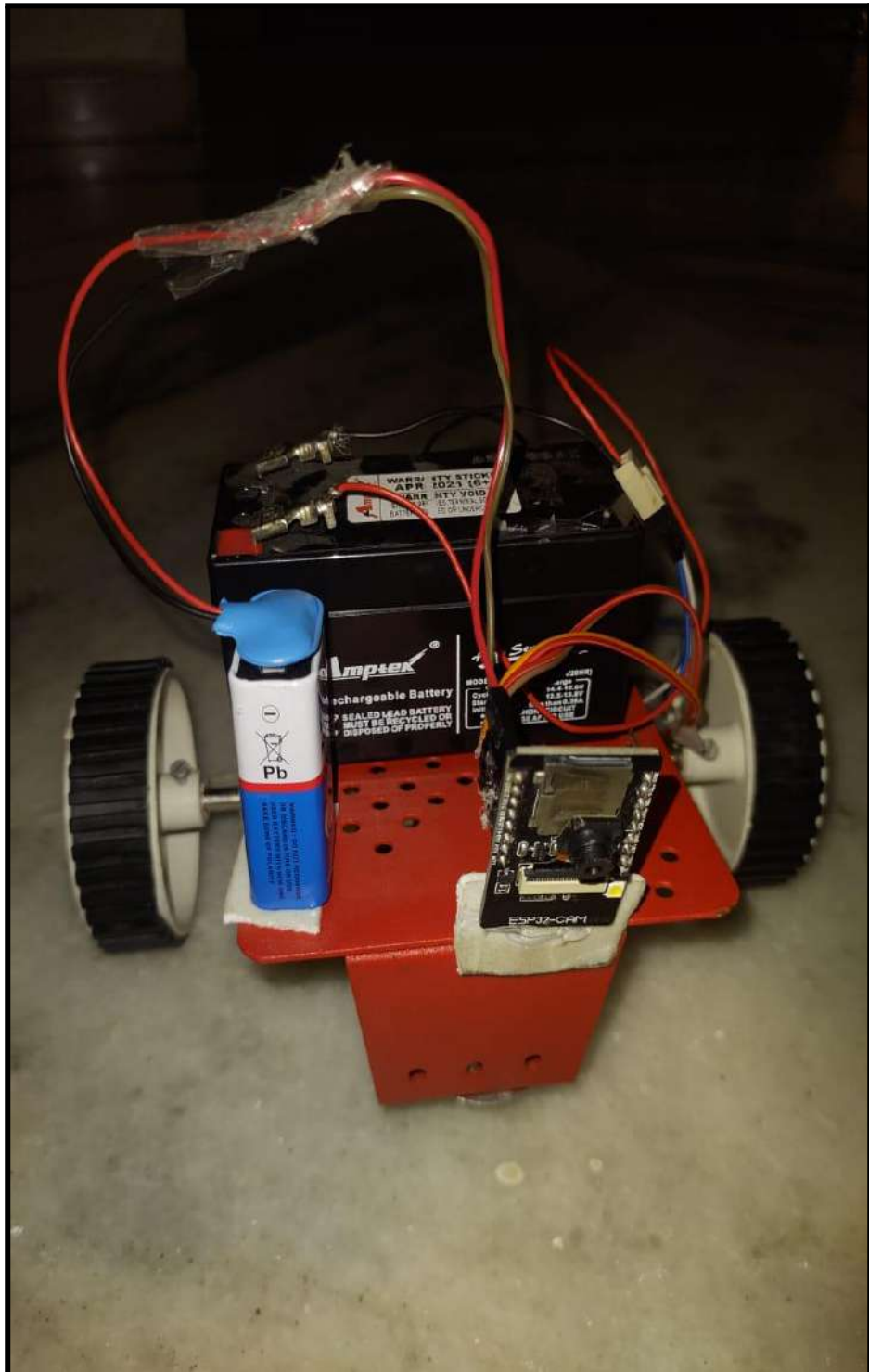

Screenshot 5.1.3 Front View Of Robot

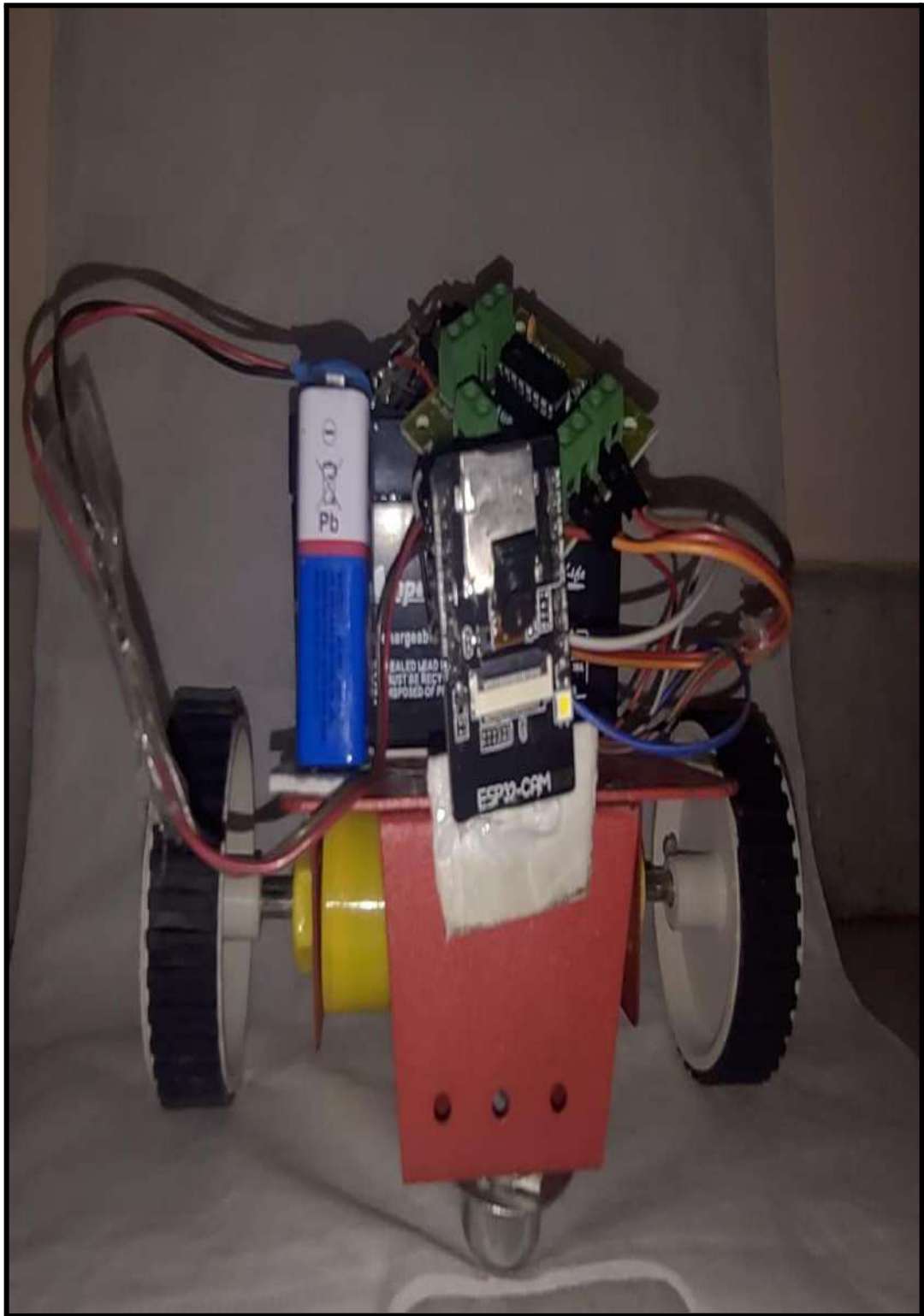

Screenshot 5.1.4 Rare View Of Robot

5.2 LIVE STREAMING

The below image shows us the user who is controlling the robot through his mobile and the robot capturing the live streaming which can be observed in the user's mobile phone.

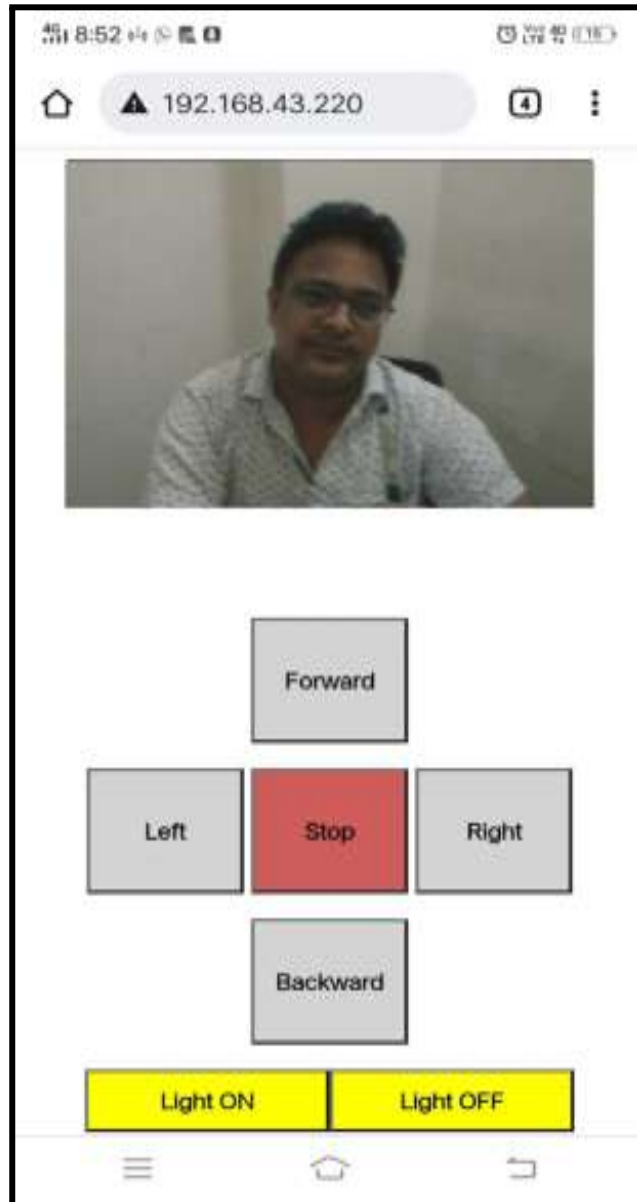

Screenshot 5.2.1 GUI Of Model

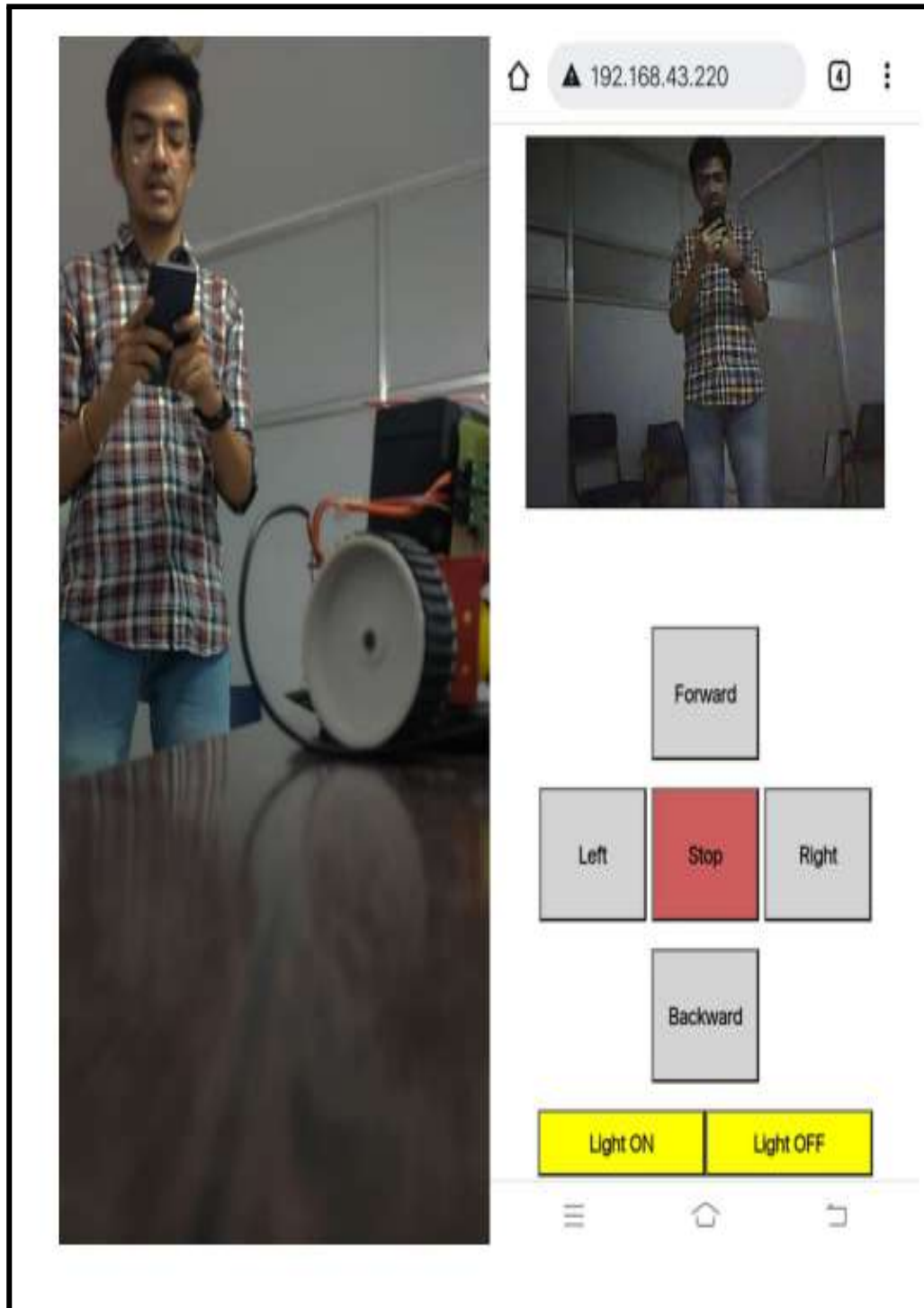

Screenshot 5.2.2 Live Streaming Captured by the Robot

5.3 GUI IN MOBILE AND LIVE STREAMING

The below image shows us the GUI of the model and robot capturing an image of a person under low light condition.

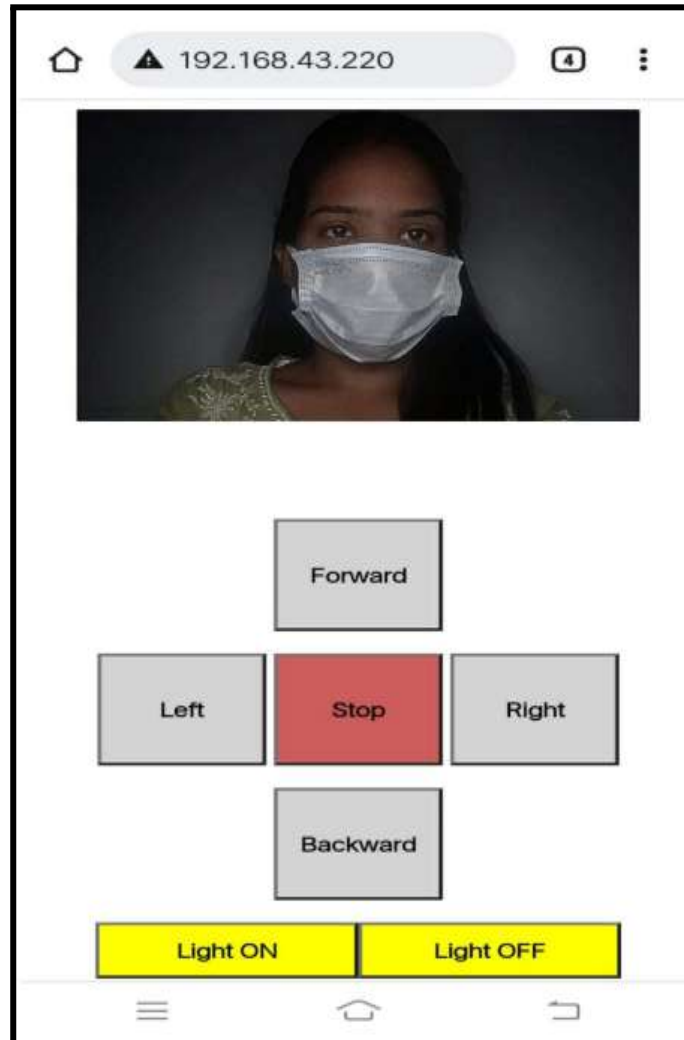

Screenshot 5.3 GUI in mobile and live streaming under low light

5.4 FUNCTION WITH LED OFF AND ON RESPECTIVELY UNDER LOW LIGHT

The below image shows us the working of LED functionality which can be turned on and off under the low light condition.

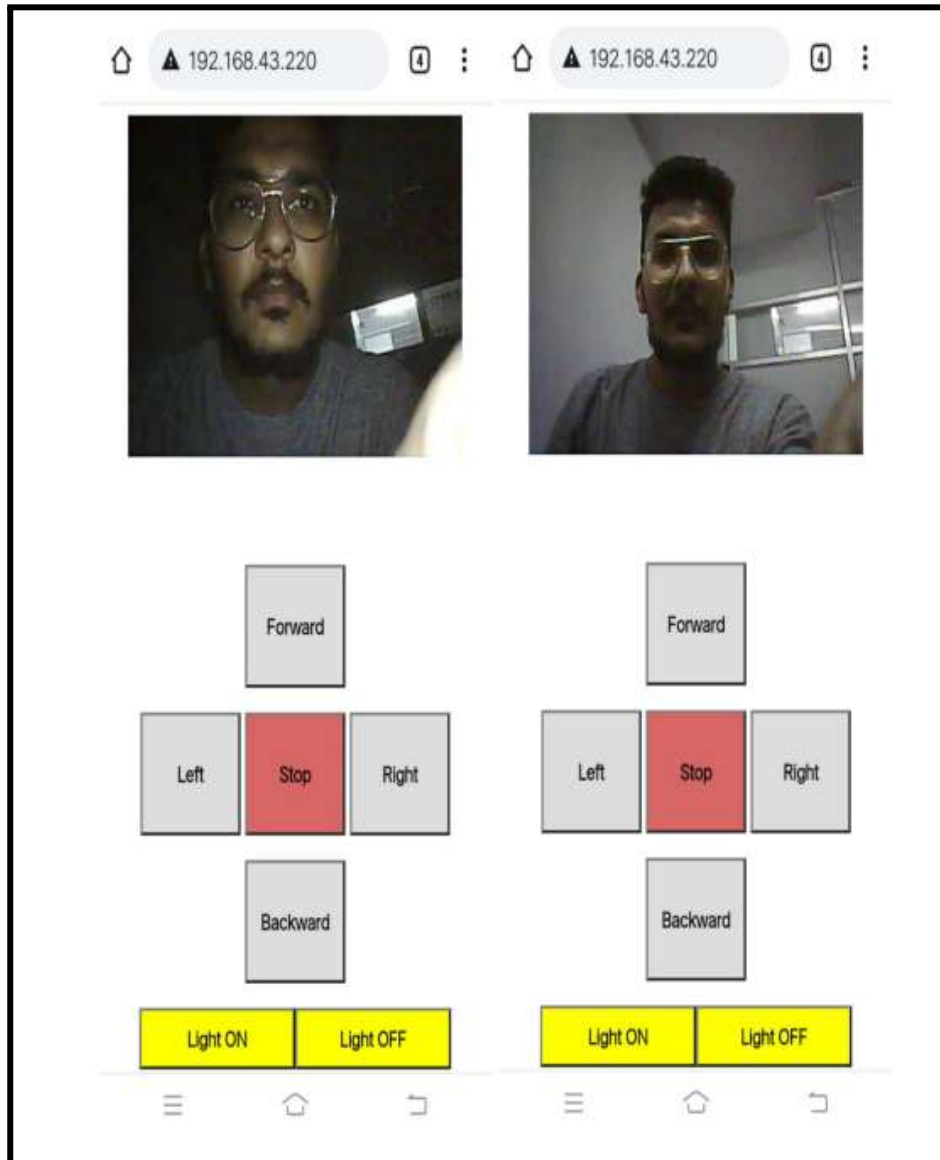

Screenshot 5.4 Functioning with LED on and off respectively

6. TESTING

6. TESTING

6.1 INTRODUCTION TO TESTING

The purpose of testing is to discover errors. Testing is the process of trying to discover every conceivable fault or weakness in a work product. It is the process of exercising software with the intent of ensuring that the Software system meets its requirements and user expectations and does not fail in an unacceptable manner.

6.2 TYPES OF TESTING

6.2.1 UNIT TESTING

Unit testing involves the design of test cases that validate that the internal program logic is functioning properly, and that program inputs produce valid outputs. All decision branches and internal code flow should be validated. It is the testing of individual software units of the application. This is structural testing that relies on knowledge of its construction and is invasive.

6.2.2 INTEGRATION TESTING

Integration tests are designed to test integrated software components to determine if they actually run as one program. Integration tests demonstrate that although the components were individually satisfactory, as shown by successfully unit testing, the combination of components is correct and consistent. Integration testing is specifically aimed at exposing the problems that arise from the combination of components.

6.2.3 FUNCTIONAL TESTING

Functional tests provide systematic demonstrations that functions tested are available as specified by the business and technical requirements, system documentation, . Functional testing is centered on the following items:

Valid Input : identified classes of valid input must be accepted

Invalid Input: identified classes of invalid input must be rejected.

Functions: identified functions must be exercised.

Output: identified classes of application outputs must be exercised.

Systems/Procedures: interfacing systems or procedures must be invoked.

6.3 TEST CASES

6.3.1 WORKING OF ROBOT

Test Case ID	Test Case Name	Purpose	Input	Output
1	Forward	To move robot forward	Press on <i>Forward</i> button	Robot moves forward
2	Backward	To move robot backward	Press on <i>Backward</i> button	Robot moves backward
3	Left	To move robot left	Press on <i>Left</i> button	Robot moves left
4	Right	To move robot right	Press on <i>Right</i> button	Robot moves right
5	Stop	To stop robot	Press on <i>Stop</i> button	Robot stops moving
6	Light On	To ON LED	Press on <i>Light ON</i> button	LED ON
7	Light Off	To OFF LED	Press on <i>Light OFF</i> button	LED OFF

Table 6.1 Results of working of Robot

7. CONCLUSION

7. CONCLUSION & FUTURE SCOPE

7.1 PROJECT CONCLUSION

The model offers live streaming of the surroundings and works with Wi-Fi, which can be switched to Bluetooth depending on user needs. It has an LED function that makes it easy to use at night. This designed model helps to monitor the surrounding area and helps to at least partially solve the mentioned problem since it is impossible to install cameras everywhere.

7.2 Future Scope

The use of artificial intelligence can extend this robot further. It can be trained as per the user's requirement and the detection of actions can be implemented. Though the idea of patrolling may not be new, the implementation of ideas makes it more convenient and readily available to any user to make use of it.

8. BIBLIOGRAPHY

8.1 REFERENCES

- [1] Chinmay Kulkarni; Suhas Grama; Pramod Gubbi Suresh; Surveillance Robot Using Arduino Microcontroller, Android APIs and the Internet, (2014) IEEE First International Conference on Systems Informatics, 83-87.
- [2] ESP32-CAM: Specification, Pinout and User Guide, Available at <https://www.arducam.com/esp32-machine-vision-learning-guide/>. Accessed on 25 May 2021.
- [3] Irfan Rangapur; B.K. Swathi Prasad; R. Suresh; Design and Development of Spherical Spy Robot for Surveillance Operation, (2020) Third International Conference on Computing and Network Communications, 1212-1220.
- [4] Kunal Borker; Rohan Gaikwad; Ajaysingh Rajput; Wireless Controlled Surveillance Robot, International Journal of Advanced Research in Computer Science and Management Studies, 2 (2), 436-441 (2014).
- [5] Mandlik Sachin B.; Bhadane Himanshu K.; Tambe Saurabh S.; and Gunjal Yogesh S.; Women Safety Night Patrolling Robot, Journal of Emerging Technologies and Innovative Research (JETIR), 6(5), 652-655 (2019).
- [6] M. Selvam; Smart Phone-Based Robotic Control for Surveillance Applications, International Journal of Research in Engineering and Technology, 3 (3), 229-232 (2014).
- [7] Wi-Fi & Bluetooth Dual Module, Available at <https://www.espressif.com/en/products/modules/esp32>. Accessed on 12 July 2021.
- [8] Xinyu Wu; Haitao Gong; Pei Chen; Zhong Zhi; Yangsheng Xu; Intelligent Household Surveillance Robot, (2008) IEEE International Conference on Robotics and Biometric, 1734-1739.

8.2 GITHUB LINK

<https://github.com/praveeshagongura/Patrolling-Robot-using-Embedded-C>

Patrolling Robot Using Embedded C

Jonnadula Narasimharao¹, Praveesha Gongura², M.V. Sreeman Bharadwaz³
and Hitesh Sirvi⁴

¹Associate Professor, Department of Computer Science and Engineering, CMR
Technical Campus, Medchal, Telangana, India.

²UG Student, Department of Computer Science and Engineering, CMR Technical Campus,
Medchal, Telangana, India.

³UG Student, Department of Computer Science and Engineering, CMR Technical Campus,
Medchal, Telangana, India.

⁴UG Student, Department of Computer Science and Engineering, CMR Technical Campus,
Medchal, Telangana, India.

ABSTRACT

Nowadays, safety, and rules are the biggest concern in many parts of the world. There are certain areas where women are being harassed, raped, etc. Not to mention that people do not obey the traffic rules or do not wear helmets. Considering the present scenario where the world just has come out of COVID-19 and is yet to deal with its variants like Delta variant and Omicron as well, people must wear masks. All of these rules are followed only if people are under surveillance due to their negligence. Unfortunately, there are no CCTVs in all areas. The government cannot keep an eye on each person. The police officer may not patrol all areas. So here, we suggest a solution to this issue by designing a patrolling robot, an IOT-based robot vehicle so that the monitoring of surrounding areas from one particular area is possible just by using a smartphone.

Keywords- Patrolling, Smartphone, ESP32 CAM, Streaming, Wi-Fi.

Date of Submission: 26-05-2022

Date of acceptance: 08-06-2022

I. INTRODUCTION

They say rules are important for one's growth and discipline and also safety is a concern for many. Is there a guarantee that these two or not be compromised? We do know that there are CCTVs only in certain areas and it is also not possible to implement them in all the areas right away. What is the problem with not having CCTV in areas? There are numerous problems like people deviating from rules such as not wearing masks, theft, suspicious persons, looking for wanted criminals, safety, abnormal events [1] etc. There is a need for a system that minimizes these issues, at least to a certain extent. The suggested robot helps users i.e., police officers or any other individual using it, to patrol and monitor the small areas where people tend to ignore traffic rules, not wearing masks as we can see, cases of COVID-19 and its variants are increasing day by day and also harassing women and many such incidents can be monitored. As there are no CCTVs in such areas, this would help reduce such cases and maintain the integrity of the citizens. The purpose is to patrol and surveillance of people in small areas or colonies where police officers do not usually patrol and to monitor people who are deviating from the rules in certain areas, taking advantage of the fact that police officers do not patrol in such areas. Individuals can also use it for purposes like home surveillance and building security. The main feature of this model is that the system uses an ESP32 CAM which is programmed and placed on the robot vehicle for monitoring its surroundings. The model can be operated using a mobile while connected to Wi-Fi and works within the range of the network it is connected to. The user controls this to monitor the live streaming. To patrol at night, an LED light is attached to the robot.

II. LITERATURE SURVEY

M. Selvam et al. have experimented with an android phone [2] and controller in this paper. He has controlled the robot using Bluetooth and the android app for certain strings are required to store in the program. Similar strings are created by the android app, and by synchronizing all together the robot is controlled using a smartphone.

Chinmay et al. designed a surveillance robot that is made with Arduino [3], but in this project, there is still the use of the internet for military applications. In certain situations, in military camps there is no possibility of interest so this system is not useful.

Kunal Borker et al. have experimented with the Android phone and the controller. You can control the robot with Bluetooth, the android app needs to store certain strings in software. Similar strings are generated by the android app, and by synchronizing all devices together, the robot is controlled [4] with a smartphone.

Irfan Rangapur et al. have built a robot in spherical shape which moves on the basis of pendulum. It comprises of Arduino nano, cameras at two ends providing 360-degree view, Pendulum and DC motor. It provides audio and video to user and runs on Bluetooth. The robot is designed to use in military tasks where it is out-of-reach to humans [5].

Mandlik Sachin B. et al. cover descriptive details about the design and implementation of a prototype in their research for an electronic gadget that has the potential to serve as safety [6] wear in the coming years. The device consists of a switch, Arduino Uno Board, GSM module (SIM900), GPS module (Neo-6M), buzzer, and pulse sensor. The device sends emergency messages using GSM.

III. PROPOSED METHOD

We propose a patrolling robot, IOT based vehicle, where the system uses cameras mounted on the robot vehicle for securing or monitoring any premises. It provides continuous monitoring through live broadcasting of the site from mobile. The police officers' control this to monitor the live streaming and when he/she sees something abnormal, then the police officer can directly go to that specific location. Fig.1 depicts the overall architecture of the designed model.

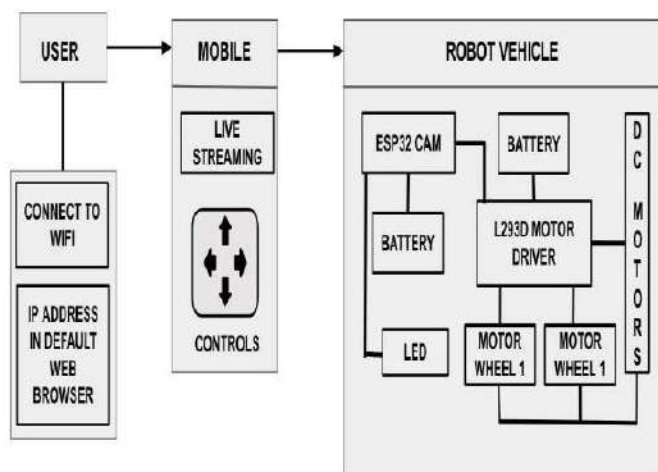

Fig.1: Diagram of Architecture

1. REQUIRED COMPONENTS

The following are the required components:

1.1 L293D Motor Driver

L293D is an Integrated Chip which comprehends two H-Bridge and PWM [7]. It comprises 16 pins with 8 pins on either side. The H-Bridge is used for rotation whereas the PWM deals with the speed of motors. The L293D motor driver drives two motors and provides a two-wheel robot vehicle functioning. It has capacitors to protect the circuit from Back EMF produced by the motors because of their inductive load.



Fig.2: L293D Motor Driver

1.2 ESP32-CAM

It is a camera module comprising an ESP32-S chip [8]. It has several GPIO pins enabling it to connect add-ons or other devices. It has the feature of a microSD card slot which stores the captured images and makes those available to users. The ESP32 CAM is programmed and we embed the code using FTDI cable through serial pins.



Fig.3: ESP32-CAM

1.3 DC Motors

Direct-Current motors are machines which make use of electrical power to convert electrical energy into mechanical energy for rotating the wheels.

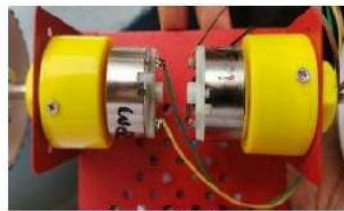

Fig.4: DC Motors

1.4 ESP32-CAM Wi-Fi and Bluetooth Module

This module enables the ESP32-CAM to connect to Wi-Fi or Bluetooth. Connecting to Wi-Fi exposes it to a larger radius [9]. However, Wi-Fi or Bluetooth can be used as per the requirements. Here we have used Wi-Fi.

2. CONNECTIONS

The two wheels are connected to the DC motors of 300rpm and these DC motors are connected to the output pins of the L293D motor driver. The L293D motor driver is an H-bridge type for which the power supply is given through the rechargeable battery and allows the bi-directional movement of wheels. The motor driver prevents back EMF. The ESP32 CAM is programmed using embedded C language. The connections are illustrated in the fig.5.

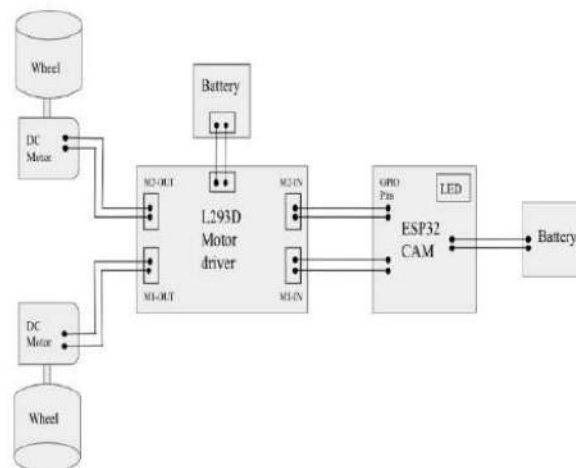

Fig.5: Diagram of Connections

The L293D motor driver comprises four input pins (IN1, IN2, IN3, IN4) which are connected to GPIO pins of ESP32 CAM, respectively [10]. The output pins (M1-OUT, M2-OUT) of the L293D motor driver are connected to each of the DC motors at 300rpm. The DC motors are attached to respective wheels for their movement. We give the power supply to ESP32 CAM through the battery. The ESP32 CAM works in both Wi-Fi and Bluetooth, here we used Wi-Fi.

3. WORKING PROCEDURE OF THE MODEL

The following are the steps involved in order to start the robot vehicle

3.1 Wi-Fi setup

Primarily, the working of the model starts with the Wi-Fi setup. Turn on the mobile's hotspot and change the hotspot name and password to "elegant" and "smartwork" respectively. Once the setup is done, it will connect the vehicle to Wi-Fi under the name "ESP32 CAM".

3.2 User interface

After connecting it to the hotspot, open the default web browser and type the IP address "192.168.43.220" in the address bar. The page with user controls and live streaming is displayed.

3.3 Controls

The page comprises the "Forward", "Backward", "Left", "Right", "Stop", "Light ON" and "Light OFF". We show the screenshot of this in figure 4.2. We can control the movement of the robot using these controls.

3.4 Live streaming

The live streaming of the areas or persons captured is shown in the user interface above the controls. We show the screenshot of this in figure 4.4 with a person standing in front of the robot and the robot being placed on the table.

IV. RESULTS

The image of the developed model is shown below



Fig.6: Image of the Robot Vehicle

1. SCREENSHOTS

The screenshots of the GUI interface are shown below with each feature

1.1 User Interface

The user interface consists of directions i.e., "Left", "Right", "Forward", "Backward" and a "Stop" button. It also comprises of "Light ON" and "Light OFF" buttons.



Fig.7: User Interface

1.2 Live Streaming

The fig.8 is the image and screenshot of live streaming respectively



Fig.8: Live Streaming of Person Standing in front of Robot

1.3 LED

The fig.9 is the screenshot of the with LED on and LED off respectively in low light with a person in front of it.

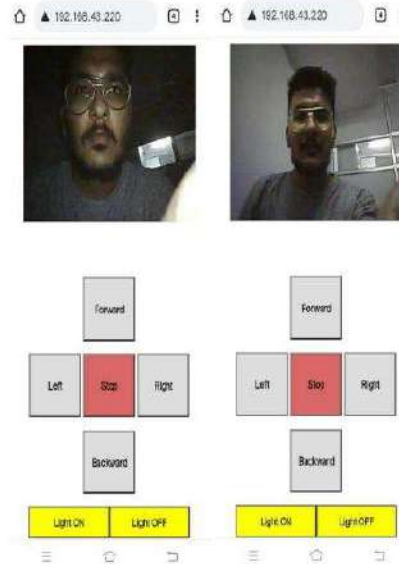

Fig.9: Screenshot of Person under Low Light with Light OFF and Light ON Respectively

V. CONCLUSION

The model offers live streaming of the surroundings and works with Wi-Fi, which can be switched to Bluetooth depending on user needs. It has an LED function that makes it easy to use at night. This designed model helps to monitor the surrounding area and helps to at least partially solve the mentioned problem since it is impossible to install cameras everywhere.

VI. FUTURE SCOPE

The use of artificial intelligence can extend this robot further. It can be trained as per the user's requirement and the detection of actions can be implemented. Though the idea of patrolling may not be new, the implementation of ideas makes it more convenient and readily available to any user to make use of it.

REFERENCES

- [1]. Xinyu Wu, Haitao Gong, Pei Chen, Zhong Zhi and Yangsheng Xu, "Intelligent Household Surveillance Robot", in 2008 IEEE International Conference on Robotics and Biometric, pp. 1734-1739, 2009.
- [2]. M. Selvam, "Smart Phone-Based Robotic Control for Surveillance Applications", International Journal of Research in Engineering and Technology, Volume 03, Issue 03, 2014.
- [3]. Chinmay Kulkarni, Suhas Grama and Pramod Gubbi Suresh, "Surveillance Robot Using Arduino Microcontroller, Android APIs and the Internet", IEEE First International Conference on Systems Informatics, pp. 83-87, 2014.
- [4]. Kunal Borker, Rohan Gaikwad and Ajaysingh Rajput "Wireless Controlled Surveillance Robot", International Journal of Advanced Research in Computer Science and Management Studies, Volume 2, Issue 2, pp. 436-441, 2014.
- [5]. Irfan Rangapur, B.K. Swathi Prasad and R. Suresh, "Design and Development of Spherical Spy Robot for Surveillance Operation", in Third International Conference on Computing and Network Communications, Volume 171, pp. 1212-1220, 2020.
- [6]. Mandlik Sachin B., Bhadane Himanshu K., Tambe Saurabh S., and Gunjal Yogesh S., "Women Safety Night Patrolling Robot", Journal of Emerging Technologies and Innovative Research (JETIR), Volume 6, Issue 5, pp. 652-655, 2019.
- [7]. Adafruit, "Arduino Lesson 15. DC Motor Reversing". Available at <https://learn.adafruit.com/adafruit-arduino-lesson-15-dc-motor-reversing/lm293d>. Accessed on 19 May 2021.
- [8]. ArduCam, "ESP32-CAM: Specification, Pinout and User Guide". Available at <https://www.arducam.com/esp32-machine-vision-learning-guide/>. Accessed on 25 May 2021.
- [9]. ESPRESSIF, "Wi-Fi & Bluetooth Dual Module". Available at <https://www.espressif.com/en/products/modules/esp32>. Accessed on 12 July 2021.
- [10]. "ESP32 with Arduino IDE". Available at <https://randomnerdtutorials.com/learn-esp32-with-arduino-ide/>. Accessed on 29 July 2021.



Certificate of Publication



This is to confirm that

Praveesha Gongura

Published following article

Patrolling Robot Using Embedded C

Volume 10, Issue 6, pp: 473-478

www.ijres.org

A Peer Reviewed referred Journal

**International Journal of Research in Engineering and
Science (IJRES)**

ISSN: 2320-9364 IJRES is Peer Reviewed Refereed.

Editor-In-Chief



Certificate of Publication



This is to confirm that

M.V. Sreeman Bharadwaz

Published following article

Patrolling Robot Using Embedded C

Volume 10, Issue 6, pp: 473-478

www.ijres.org

A Peer Reviewed referred Journal

**International Journal of Research in Engineering and
Science (IJRES)**

Editor-In-Chief

ISSN: 2320-9364 IJRES is Peer Reviewed Refereed.



Certificate of Publication



This is to confirm that

Hitesh Sirvi

Published following article

Patrolling Robot Using Embedded C

Volume 10, Issue 6, pp: 473-478

www.ijres.org

A Peer Reviewed referred Journal

**International Journal of Research in Engineering and
Science (IJRES)**

Editor-In-Chief

ISSN: 2320-9364 IJRES is Peer Reviewed Refereed.